

INSTRUCTRETRO: INSTRUCTION TUNING POST RETRIEVAL-AUGMENTED PRETRAINING

Boxin Wang^{1†}, Wei Ping^{1†}, Lawrence McAfee¹, Peng Xu¹

Bo Li², Mohammad Shoeybi¹, Bryan Catanzaro¹

¹ NVIDIA ² University of Illinois at Urbana-Champaign

†{boxinw, wping}@nvidia.com

ABSTRACT

Pretraining auto-regressive large language models (LLMs) with retrieval demonstrates better perplexity and factual accuracy by leveraging external databases. However, the size of existing pretrained retrieval-augmented LLM is still limited (e.g., *Retro* has 7.5B parameters), which limits the effectiveness of instruction tuning and zero-shot generalization. In this work, we introduce *Retro* 48B, the largest LLM pretrained with retrieval before instruction tuning. Specifically, we continue to pretrain the 43B GPT model on additional 100 billion tokens using the Retro augmentation method by retrieving from 1.2 trillion tokens. The obtained foundation model, Retro 48B, largely outperforms the original 43B GPT in terms of perplexity. After instruction tuning on Retro, *InstructRetro* demonstrates significant improvement over the instruction tuned GPT on zero-shot question answering (QA) tasks. Specifically, the average improvement of *InstructRetro* is 7% over its GPT counterpart across 8 short-form QA tasks, and 10% over GPT across 4 challenging long-form QA tasks. Surprisingly, we find that one can ablate the encoder from *InstructRetro* architecture and directly use its decoder backbone, while achieving comparable results. We hypothesize that pretraining with retrieval makes its decoder good at incorporating context for QA. Our results highlights the promising direction to obtain a better GPT decoder for QA through continued pretraining with retrieval before instruction tuning.

1 INTRODUCTION

Retrieval helps large language models (LLM) to handle current events, detailed knowledge, proprietary information not in pretraining, and to improve factual grounding (e.g., Nakano et al., 2021; Thoppilan et al., 2022; Borgeaud et al., 2022). In the previous study, pretraining auto-regressive language model with retrieval (i.e., *Retro*) demonstrates successes in reducing perplexity (Borgeaud et al., 2022) and improving factual accuracy (Wang et al., 2023a).

In the past year, the decoder-only auto-regressive LLMs have demonstrated remarkable successes (e.g., OpenAI, 2022; 2023), because *i*) LLMs have been scaled to hundreds of billion parameters (Brown et al., 2020a; Rae et al., 2021; Smith et al., 2022; Chowdhery et al., 2022), *ii*) pretraining corpus has been scaled up to trillions of tokens (Hoffmann et al., 2022; Touvron et al., 2023a;b), and *iii*) instruction tuning (Wei et al., 2022a; Chung et al., 2022) and reinforcement learning from human feedback (RLHF) (Ouyang et al., 2022) recipes have been applied on these pretrained LLMs. In contrast, the pretrained retrieval-augmented language models still have relatively small number of parameters trained limited number of tokens. For example, the auto-regressive *Retro* has 7.5B parameters and is trained on 600B tokens (Borgeaud et al., 2022), *Retro++* has 9.5B parameters and is trained on 330B tokens (Wang et al., 2023a), and T5-based *Atlas* has 11B parameters and is trained with retrieval on maximum 327M tokens (Izacard et al., 2022c). The lack of scaling limits the effectiveness of instruction tuning (Wei et al., 2022a) and other intriguing properties that exist in large language models (Wei et al., 2022b).

In this work, we scale up *Retro* up to 48B parameters, trained on 1.2T tokens in total, i.e., 1.1T tokens for pretraining its GPT backbone, 100B tokens for continued retrieval-augmented pretraining while

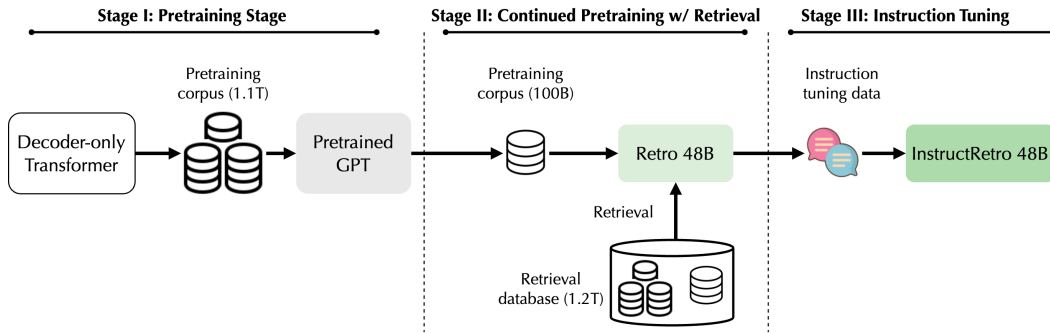

Figure 1: Training pipeline for InstructRetro 48B.

retrieving from 1.2T tokens. As a result, we can mitigate the zero-shot generalization gap on question answering tasks after applying instruction tuning.

Specifically, we make the following contributions:

1. We introduce *Retro 48B*, the largest LLM pretrained with retrieval. To save the computation budget, we continue to pretrain a 43B parameter GPT model (originally trained on 1.1T tokens) on additional 100B tokens by retrieving from 1.2T tokens. In contrast to *Retro-fitting* (Borgeaud et al., 2022), that freezes pretrained decoder weights, we unfreeze the decoder, jointly train all the parameters and find better perplexity.¹ Notably, we find the perplexity improvement of *Retro 48B* over its GPT 43B counterpart is still significant even at this scale.
2. After instruction tuning, *InstructRetro 48B* demonstrates strong zero-shot capability to incorporate context for question answering (QA), and significantly outperforms its GPT counterpart using the same instruction tuning recipe. The full pipeline to train *InstructRetro* is shown in Figure 1.
3. Perhaps surprisingly, we find that one can directly ablate the encoder from *InstructRetro* and still obtain comparable results on zero-shot QA tasks. This highlights the promising direction of obtaining better decoder-only LLMs through continued pretraining with retrieval before instruction tuning.

We organize the rest of the paper as follows. We discuss related work in Section 2, and introduce the continued pretraining of *Retro 48B* in Section 3. We present the instructing tuning in Section 4. We report results in Section 5 and conclude the paper in Section 6.

2 RELATED WORK

Retrieval-augmented language models have been established for open domain question answering for years (Karpukhin et al., 2020; Lewis et al., 2020; Guu et al., 2020; Borgeaud et al., 2022; Izacard et al., 2022c). In the previous study, language models have been augmented with retrieval at inference (Khandelwal et al., 2020; Yogatama et al., 2021), fine-tuning (Karpukhin et al., 2020; Lewis et al., 2020; Guu et al., 2020; Huang et al., 2023), and pretraining (Borgeaud et al., 2022; Izacard et al., 2022c; Wang et al., 2023a). Retrieval-augmented pretraining is particularly interesting, as it can largely reduce model perplexity (Borgeaud et al., 2022), enhance factuality (Wang et al., 2023a), and improve downstream task accuracy after task-specific fine-tuning (Izacard et al., 2022c).

In contrast to the state-of-the-art decoder-only LLMs with hundreds of billion parameters (Brown et al., 2020b; Rae et al., 2021; Smith et al., 2022; Chowdhery et al., 2022), the sizes of pretrained retrieval-augmented LLMs are still around 10B parameters (Borgeaud et al., 2022; Wang et al., 2023a; Izacard et al., 2022b), which largely limits the zero-shot generalization capability after instruction tuning (Wei et al., 2022a; Ouyang et al., 2022; Chung et al., 2022). For example, Wei et al. (2022a) finds instruction tuning becomes effective when the decoder-only LLM has around 50B parameters.

¹Note that, it turns out that unfreezing of decoder is an important design not only for better perplexity, and it eventually leads to the interesting finding after instruction tuning.

Instruction tuning aims to teach LLMs to follow natural language instructions (Wei et al., 2022a; Ouyang et al., 2022; Sanh et al., 2022b; Mishra et al., 2022), which becomes an indispensable ingredient to build the state-of-the-art LLMs for chat and QA tasks (OpenAI, 2022; 2023; Touvron et al., 2023b). In the past years, many high-quality instruction tuning datasets have been created, e.g., FLAN (Chung et al., 2022), OpenAssistant (Köpf et al., 2023), and Dolly (Conover et al., 2023).

3 CONTINUED PRETRAINING OF GPT WITH RETRIEVAL

In this section, we start by introducing the preliminaries of *Retro* (Borgeaud et al., 2022) and highlight some key differences between Retro and GPT. We then go through the pretraining details of how we scale up the size of Retro to 48B, a size that has never been studied before.

3.1 PRELIMINARIES OF RETRO

Retro (Borgeaud et al., 2022) is an auto-regressive language model pretrained with retrieval augmentation. While Retro shares the backbone of GPT models, Retro differs from GPT by incorporating an additional *Retro encoder*. The Retro encoder is adept at encoding features of retrieved neighbors from *external knowledge bases*. Furthermore, Retro adds *chunk-wise cross-attention* layers within its decoder transformer architecture to integrate retrieved information from the Retro encoder effectively. This design paradigm also makes Retro different from the encoder-decoder architecture (e.g., T5 (Raffel et al., 2020) and Atlas (Izacard et al., 2022b)). The success of scaling decoder-only autoregressive language models (e.g., ChatGPT (OpenAI, 2022) and GPT-4 (OpenAI, 2023)) motivates us to further scale up Retro and understand the potential benefit of retrieval-augmented pretraining.

Retro encoder is a shallow bidirectional transformer to encode retrieved neighbors from external databases into dense features. Specifically, in this work, we follow Borgeaud et al. (2022) and use a two-layer bidirectional transformer as the Retro encoder with the same hidden dimension as the Retro backbone decoder. Our preliminary results show that increasing the layers of the Retro encoder does not bring better perplexity on the validation set but increases the computational overhead and model parameters.

Retrieval database. Borgeaud et al. (2022) demonstrates that retrieval-augmented pretraining can significantly benefit from large-scale retrieval up to trillions of tokens. To build the retrieval database, we utilize the entire pretraining corpus, but holding out 1% as a validation set. This ensures that both Retro and GPT models are pretrained on an equivalent volume of information from the pretraining corpus. Our retrieval database is a key-value database, where values are chunks of tokens split from the pretraining corpus, and the keys are corresponding BERT embeddings (Devlin et al., 2018). The pretraining corpus consists of 1.2 trillion tokens of English corpus. More details of the pretraining corpus can be found in Appendix §A.1. In summary, our retrieval database comprises 19 billion chunks, with each chunk containing 64 tokens.

Chunk-wise cross-attention. Aligning with the chunk-wise design of the retrieval database, Retro splits the input tokens into a sequence of chunks. Specifically, Retro retrieves nearest neighbor chunks using the previous chunk and fuses this information with the context from preceding chunks to guide the generation of the next chunk. Formally, given an input sequence X with n tokens $X = (x_1, \dots, x_n)$, Retro splits X into a sequence of l chunks (C_1, \dots, C_l) with chunk size $m = \frac{n}{l}$. From a high-level perspective, Retro uses the last $(i - 1)$ -th chunk C_{i-1} to retrieve k nearest neighbor chunks $\mathcal{N}(C_{i-1})$ from the retrieval database, and fuses the contextual information from the previous chunks (C_1, \dots, C_{i-1}) and retrieval information from $\mathcal{N}(C_{i-1})$ by cross-attention to guide the generation of the next (i) -th chunk C_i . To avoid breaking the causality, the autoregressive generation of i -th chunk C_i can only use the nearest neighbors of the previous chunk $\mathcal{N}(C_{i-1})$ instead of $\mathcal{N}(C_i)$. In our work, we follow Borgeaud et al. (2022) and retrieve top- $k = 2$ nearest neighbors for each chunk, with chunk size $m = 64$ and the maximum number of tokens $n = 4096$.

3.2 RETRO-FITTING: CONTINUED PRETRAINING WITH RETRIEVAL

There are two main challenges of scaling up Retro: the large-scale retrieval database and the huge pretraining cost. To overcome the challenges, we leverage the *Faiss* index (Johnson et al., 2019) to

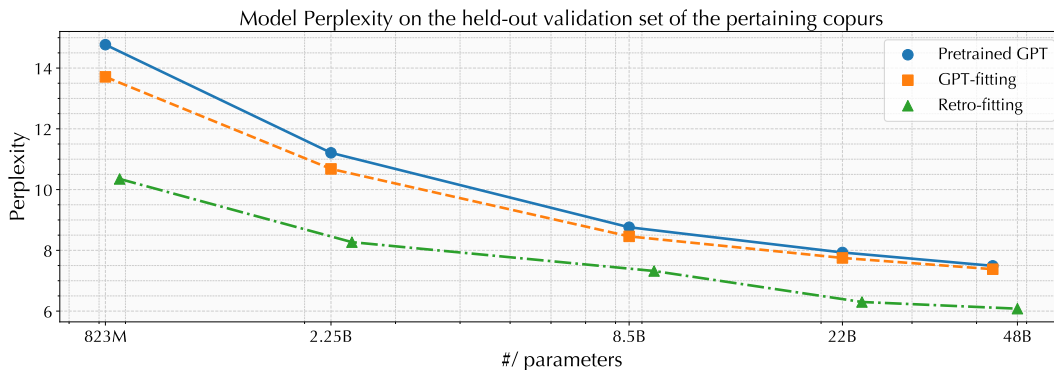

Figure 2: Perplexity evaluation of pretrained GPT models, GPT-fitting, and Retro-fitting models across various parameter sizes on the held-out validation set. In contrast to Borgeaud et al. (2022), we unfreeze all parameters for Retro-fitting. Retro significantly outperforms GPT models, achieving the perplexity comparable to GPT models with 4× larger parameter sizes.

achieve fast approximate nearest neighbor search and *retro-fitting* techniques to reuse the pretrained GPT parameters and save computational cost.

Retrieval index to the large-scale retrieval database. We use the Faiss index (Johnson et al., 2019) as the implementation for the dense retriever to search for approximate nearest neighbors in the BERT embedding space. We configure the Faiss index to cluster the dense embeddings into 2^{22} centroids accelerated with Hierarchical Navigable Small World (HNSW) graphs (Malkov & Yashunin, 2018) to speed up the query. We also encode the embeddings with optimized product quantization (Gray & Neuhoff, 1998; Ge et al., 2014) to compress memory overhead and further improve the query throughput. As a result, we can achieve $4ms$ per query over the whole pretraining corpus averaged for each chunk on a DGX-A100 node. One may find more details in Appendix §B.

Unfreezing decoder at Retro-fitting. As Retro shares its backbone decoder with the GPT decoder and only adds around 10% additional parameters for Retro encoder and cross-attention, we can initialize Retro decoder from pretrained GPT models, randomly initialize Retro encoder and cross-attention, and continue pertaining with retrieval, which is named as “*Retro-fitting*”. Note that, Borgeaud et al. (2022) freezes the decoder parameters at Retro-fitting. In contrast, we **unfreeze all the decoder parameters** and continue pertaining the entire model. We also conduct an ablation study of Retro-fitting based on a pretrained GPT of 823M parameters and compare the validation perplexity loss when freezing or unfreezing Retro decoder during pretraining. As shown in Figure 3, given the same training schedules, unfreezing Retro decoder parameters converges faster and demonstrates better validation perplexity, which eventually yields a better Retro decoder to incorporate in-context retrieved evidence, even without a Retro encoder as shown in §5.3. We continue pertaining with retrieval on an additional 100 billion tokens, which is 9% of the pertaining data used for pretrained GPT models. To have a fair comparison, we also continue pretraining GPT foundation models on the same 100 billion tokens, which we name “*GPT-fitting*”. More pretraining details can be found in Appendix A.2.

Base pretrained GPT. We launch continue pertaining (*i.e.*, GPT-fitting and Retro-fitting) based on pretrained GPT models. Specifically, we pretrain from scratch a set of GPT models with the following parameter sizes: 823M, 2.25B, 8.5B, 22B, and 43B. All of the models are based on Transformer (Vaswani et al., 2017) with different hidden dimensions, number of layers, and attention heads. We adopt the Sentence Piece tokenizer (Kudo & Richardson, 2018) for both GPT and Retro. We pretrain all models with 1.1 trillion tokens of the pertaining corpus. More details can be found in Appendix §A.

Perplexity evaluation. We evaluate the perplexity of GPT foundation models, GPT-fitting models, and Retro-fitting models of varying parameter sizes in Figure 2. The validation corpus consists of 1% held-out samples from the pertaining corpus, which are not used in the pertaining stage, the continued pertaining stage, and the retrieval database to ensure that there is no validation data leakage. From Table 2, one can see that after continued pretraining on additional 100 billion tokens, the perplexity of

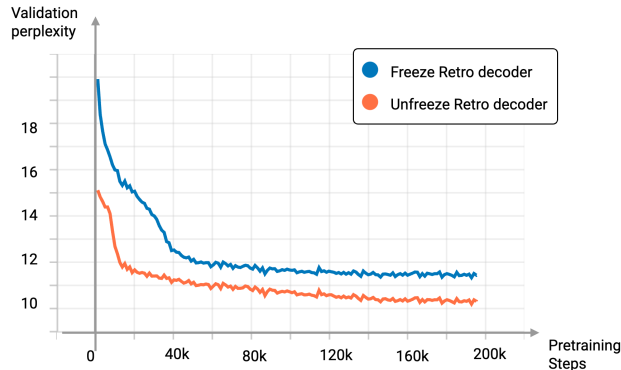

Figure 3: Validation perplexity of Retro-fitting when we freeze or unfreeze Retro decoder during continued pretraining on 100B tokens.

GPT-fitting slightly improves, while Retro significantly outperforms both GPT and GPT-fitting across different parameter sizes in terms of perplexity. Specifically, Retro achieves even better perplexity than GPT models with $4\times$ larger parameter sizes, and the trend of improvement does not diminish when the parameter sizes of Retro scale up to 48B. We present more evaluation results in §5.3.

4 INSTRUCTION TUNING

Instruction tuning can significantly improve the ability of foundation LLMs to follow instructions, thus improving zero-shot results on downstream tasks (e.g., Wei et al., 2022a; Chung et al., 2022). In this section, we further enhance Retro via instruction tuning.

4.1 DATASETS BLENDING

Existing instruction tuning methods mainly leverage two training paradigms: supervised fine-tuning on a blend of instruction datasets (Wei et al., 2022a; Chung et al., 2022; Sanh et al., 2022a; Wang et al., 2023b) or reinforcement learning through human feedback (RLHF) (Ouyang et al., 2022; Bai et al., 2022; OpenAI, 2023). Due to the limited open-source human feedback data, we focus on supervised instruction tuning for Retro to unveil the potential of retrieval-augmented LLMs.

We use a blend of high-quality instruction tuning datasets to train LLMs to follow instructions in conversational formats, which include: *i*) a high-quality social dialogue dataset SODA (Kim et al., 2022), *ii*) a long-form QA dataset ELI5 that requires elaborate answers (Fan et al., 2019), *iii*) LLM-generated instructions: Self-Instruct (Wang et al., 2022) and Unnatural Instructions (Honovich et al., 2022), *iv*) FLAN and Chain-of-thought datasets (Chung et al., 2022; Wei et al., 2022c; Longpre et al., 2023), *v*) a private crowd-sourced conversational dataset and public human-written conversation datasets OpenAssistant (Köpf et al., 2023) and Dolly (Conover et al., 2023), and *vi*) samples from the pretraining corpus.

The format of all the instruction tuning data is unified in a conversational way with three roles: “system”, “assistant”, and “user”. The “system” role sets up the tone and style of LLM assistants to give helpful, detailed, and polite answers to the user’s questions. The “user” and “assistant” role contains the questions and the corresponding answers from the instruction tuning datasets. We show an example format of the instruction data in Appendix C.1. In total, we collect a total of 128K high-quality samples for instruction tuning.

4.2 TRAINING DETAILS

For each training sample, we take the multi-turn conversations between the user and the assistant as context and apply the loss mask only to the last response from the assistant. We use the standard language modeling loss with teacher forcing. Since Wei et al. (2022a) suggests that instruction tuning is most effective with *large* language models, we apply instruction tuning to the GPT-fitting

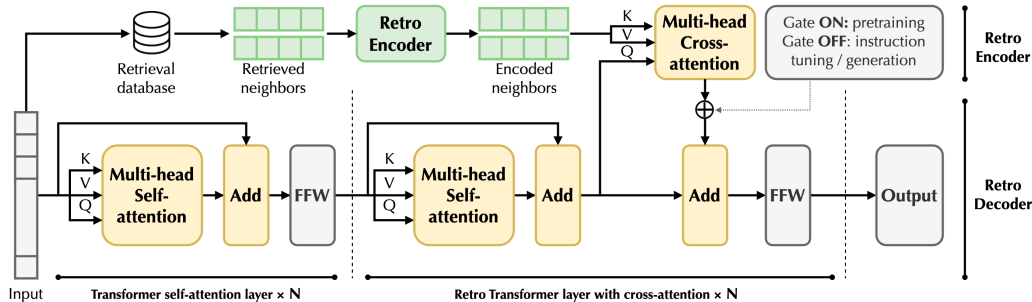

Figure 4: Retro simplified architecture diagram. We omit the layer norm, softmax, and embedding layers for simplicity. We add additional 0/1 gates between cross-attention output and the residual connection from self-attention output. During pretraining, we keep the Retro encoder gate ON (one). During instruction tuning and inference, we turn the Retro encoder gate OFF (zero) when there is no retrieved neighbors.

43B model and the Retro 48B model, naming them “GPT-Instruct 43B”² and “InstructRetro 48B”, respectively. We finetune the LLMs by taking the loss only on the answer part with a batch size of 128 and a learning rate of 5e-6 for 1000 steps with a weight decay of 0.01. We use the Adam optimizer (Kingma & Ba, 2014) with $\beta_1 = 0.9$ and $\beta_2 = 0.98$.

Instruction tuning for Retro. Since the Retro backbone largely shares with GPT models, the training objective of Retro is also the same as GPT models. However, one noticeable difference is that Retro requires retrieval of nearest neighbors for the input instructions, which is not available from all the instruction tuning datasets. Since the instruction tuning data is high-quality, retrieval from the pertaining corpus can yield noisy neighbors, thus not helping improve the model capabilities to follow instructions. We instead skip the cross-attention connection through a manually-set gated mechanism as detailed in Figure 4, which sets the gate to *zero* when retrieved neighbors are not available. During backpropagation, as the cross-attention module and the connected retro encoder are skipped, their parameters are effectively frozen, and only the weights of decoder backbone gets updated. The design makes Retro learn to inference with and without retrieval during instruction tuning, potentially improving the generalization of the Retro decoder. We also leave it as an important future direction to construct retrieval-augmented instruction tuning data for retrieval-augmented generation.

5 EXPERIMENT

In this section, we conduct comprehensive studies on the zero-shot capabilities of *InstructRetro* and its GPT counterpart across various downstream tasks to unveil the potential of Retro 48B after instruction tuning.

5.1 EXPERIMENTAL SETUP

Datasets. We follow the literature of retrieval-augmented generation (RAG) (Lewis et al., 2020; Karpukhin et al., 2020; Izacard et al., 2022a; Wang et al., 2023a) and evaluate InstructRetro 48B and GPT-Instruct 43B on a wide range of open-ended Question Answering (QA) datasets. To demonstrate the generalization of instruction tuning, we follow FLAN (Wei et al., 2022a) and primarily focus on *zero-shot evaluation* of QA datasets. Specifically, we consider two categories of open-ended QA datasets: (1) *short-form QA datasets*, which expect short answers (answers within a few tokens), including Natural Question (NQ) (Kwiatkowski et al., 2019), TriviaQA (Joshi et al., 2017), NewsQA (Trischler et al., 2016), SQuAD 1.1 (Rajpurkar et al., 2016), SQuAD 2.0 (Rajpurkar et al., 2018), Quoref (Dasigi et al., 2019), NarrativeQA (Kočíšký et al., 2018), DROP (Dua et al., 2019); (2) *long-form QA datasets*, which expect longer answer spans within a few sentences. As the ELI5 (Fan et al., 2019) dataset is used in the instruction tuning stage, we exclude it from the zero-shot long-form QA evaluation. We instead focus on the following long-form QA datasets: doc2dial (Feng et al., 2020),

²We distinguish “GPT-Instruct”, which uses supervised fine-tuning, from “InstructGPT” (Ouyang et al., 2022), which leverage RLHF for instructing tuning.

Table 1: Zero-shot evaluation on eight short-form QA datasets. The average *relative* improvement of InstructRetro across the short-form QA tasks is 7% over GPT-Instruct.

Task	NQ	TriviaQA	NewsQA	SQuAD 2.0	SQuAD 1.1	Quoref	NarrativeQA	DROP
Metric	EM	EM	F1	F1 / EM	F1 / EM	F1	F1	F1
GPT-3 175B (Brown et al.) (Chowdhery et al.)	14.6	64.3	-	59.5 / 52.6	-	-	-	23.6
PaLM 2 -L (Chowdhery et al.)	37.5	-	-	- / -	-	-	-	-
Llama 65B (Touvron et al.)	23.8	68.2	-	- / -	- / 79.4	-	-	-
Llama 2 70B (Touvron et al.)	25.3	-	-	- / -	- / 80.7	-	-	-
GLaM 64B (Du et al.)	24.7	71.3	-	71.1 / 64.7	- / -	-	-	57.3
FLAN-LaMDA 137B (Wei et al.)	20.7	68.1	-	44.2 / -	80.1 / -	-	-	22.7
Retro 7.5B (Borgeaud et al.)	8.9	36.0	-	- / -	-	-	-	-
Retro++ 9B (Wang et al.)	25.8	48.3	-	- / -	-	-	-	-
Atlas 11B (Izacard et al.)	26.7	56.9	-	- / -	- / -	-	-	-
Raven 11B (Huang et al.)	29.6	65.7	-	- / -	- / -	-	-	-
GPT-Instruct 43B	37.0	65.0	52.4	70.7 / 64.3	72.4 / 65.8	71.5	53.9	51.8
InstructRetro 48B (Avg: +7%)	38.9 (+5.14%)	65.6 (+0.92%)	57.4 (+9.54%)	75.6 / 69.3 (+6.93%)	77.1 / 70.4 (+6.49%)	76.2 (+6.57%)	60.0 (+11.32%)	54.8 (+5.79%)

two proprietary annotated car manual datasets (people ask questions about the particular model of a car), and another proprietary annotated IT dataset.

Baselines. GPT-Instruct 43B is our main baseline as both GPT-Instruct 43B and InstructRetro 48B have the same GPT decoder hyper-parameters (e.g., number of transformer layers, hidden sizes, etc.) and was pretrained and instruction-tuned on the same amount of data. In addition, we also compare a wide range of state-of-the-art large language models with comparable or larger sizes, including GPT-3 175B (Brown et al., 2020b), Llama 65B (Touvron et al., 2023a), Llama 2 70B (Touvron et al., 2023b), GLaM 64B (Du et al., 2021), and FLAN-LaMDA 137B (Wei et al., 2022a). Furthermore, we also compare InstructRetro 48B with existing retrieval-augmented LLMs, including Retro 7.5B (Borgeaud et al., 2022), Retro++ 9B (Wang et al., 2023a), Atlas 11B (Izacard et al., 2022b), and Raven 11B (Huang et al., 2023).

Implementation details. We use greedy decoding for open-ended QA with the max output length to be 256. We truncate the generation when we encounter the special token `|<end-of-document>|` or role-switching from “Assistant” to “User” when completing the conversation. All of the QA tasks are re-formatted in the conversational format. An example from the SQuAD 1.1 dataset in the conversational prompt format is shown in Appendix Table 7. Most of the QA tasks provide retrieved relevant contexts, which are also incorporated into the prompt. As the Natural Question and TriviaQA datasets do not provide relevant contexts, we take the top-5 DPR-retrieved passages (Karpukhin et al., 2020) as contexts and put them into the prompts. As we do instruction tuning on Retro without enabling its encoder, we also bypass the Retro encoder during evaluation, **making it serve solely as a GPT decoder** to align with the instruction tuning behaviors.

Table 2: Zero-shot evaluation on four long-form QA datasets. We use F1 as the evaluation metric. The average *relative* improvement of InstructRetro across the long-form QA tasks is 10% over GPT-Instruct.

	doc2dial	Car Manual Doc #1	Car Manual Doc #2	IT Doc
GPT-Instruct 43B	32.87	58.18	50.88	31.40
InstructRetro 48B	35.74	63.52	57.49	34.08
(avg: +10%)	(+8.73%)	(+9.18%)	(+12.99%)	(+8.54%)

5.2 ZERO-SHOT EVALUATION AFTER INSTRUCTION TUNING

We present the zero-shot evaluation results across eight short-form QA datasets in Table 1. We also apply InstructRetro to four open-ended long-form QA datasets, as detailed in Table 2. These datasets are representative of real-world applications, including chatbots for IT support and customer service.

Instruction tuning post retrieval-augmented pretraining yields a better GPT decoder. From both Table 1 and 2, we observe that InstructRetro shows consistent accuracy improvement upon its counterpart GPT-Instruct across different datasets for both short-form and long-form QA. Notably, the average relative improvement of InstructRetro across all the short-form datasets is around 7%. Note that, InstructRetro bypasses its Retro encoder during evaluation, operating solely as a GPT decoder. Given that both InstructRetro and GPT-Instruct are pretrained and instruction tuned with identical datasets, hyper-parameters, and evaluation prompts, we attribute this consistent improvement to the training recipe of InstructRetro, which leverages continued pretraining with retrieval before instruction tuning. To have a deeper understanding, we execute an ablation study, detailed in §5.3.

From Table 1, we also show that our InstructRetro provides compelling performance than other state-of-the-art LLMs. For example, InstructRetro 48B achieves better accuracy than GLaM 64B on multiple datasets (e.g., NQ and SQuAD 2.0), close to FLAN-LaMDA 137B.

InstructRetro demonstrates larger improvement on long-form QA datasets. When comparing the results of InstructRetro on short-form QA datasets and long-form QA datasets, we observe InstructRetro demonstrates large relative accuracy improvements, achieving 10% over the GPT-Instruct. As long-form QA tasks are generally more challenging than short-form QA tasks, such improvements further demonstrate the potential of retrieval-augmented pretraining.

5.3 ABLATION STUDIES

In this section, we conduct ablation studies to understand the source of improvements for InstructRetro. We show that both retrieval-augmented pretraining and instruction tuning are indispensable to unlock the potential of retrieval-augmented LLMs.

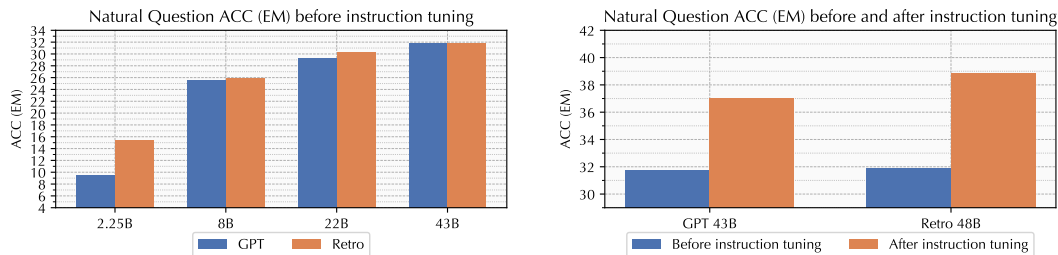

(a) Before instruction tuning, the improvement of retrieval augmentation saturates when the size scales up.

(b) Instruction tuning further unveils the potential of retrieval augmentation even when the size scales up.

Figure 5: Zero-shot accuracy (EM) of GPT and Retro before and after instruction tuning evaluated on the Natural Question dataset.

Ablation study on instruction tuning. To understand how instruction tuning improves retrieval-augmented pretraining, we show the zero-shot accuracy (Exact Match) of Retro and GPT on the Natural Question dataset before and after instruction tuning, as detailed in Figure 5. We observe that Retro achieves significantly better zero-shot accuracy than GPT when the number of parameters is

Table 3: Zero-shot evaluation on short-form QA tasks. We ablate with encoder (enc.) and without it.

Task	NQ	TriviaQA	NewsQA	SQuAD 2.0	SQuAD 1.1	Quoref	NarrativeQA	DROP
Metric	EM	EM	F1	F1 / EM	F1 / Em	F1	F1	F1
InstructRetro w/ enc.	38.6	65.4	57.0	74.8 / 67.7	76.4 / 69.0	76.1	59.8	54.6
InstructRetro w/o enc.	38.9	65.6	57.4	75.6 / 69.3	77.1 / 70.4	76.2	60.0	54.8

Table 4: Zero-shot evaluation on long-form QA tasks. We use F1 as the evaluation metric. We ablate with encoder (enc.) and without it.

	doc2dial	Car Manual Doc 1	Car Manual Doc 2	IT Doc
InstructRetro w/ enc.	35.95	63.16	56.82	34.07
InstructRetro w/o enc.	35.74	63.52	57.49	33.71

relatively small (e.g., 2.25B). However, when scaling the size of parameters, the zero-shot performances of both GPT and Retro start to saturate. We hypothesize that this saturation is mainly due to the poor instruction following abilities of both pretrained foundation GPT and Retro models.

To improve their instruction following ability, we apply instruction tuning to further fine-tune both Retro 48B and GPT 43B. Instruction tuning largely mitigate the instruction following bottleneck for both GPT and Retro, resulting in a significant increase of their zero-shot performance on downstream tasks, respectively. Furthermore, once this bottleneck is alleviated, the benefits of retrieval augmentation at pretraining become more pronounced, as InstructRetro excels in leveraging and integrating evidence from retrieved context. Thus, we observe significant improvement of InstructRetro over GPT-Instruct again in Figure 5b. The same trend also holds for the TriviaQA dataset, as shown in Appendix Figure 6. This ablation study confirms that our training recipe, both retrieval-augmented pretraining and instruction tuning are important for achieving high performance in QA tasks.

Ablation study on Retro encoder. We enable the Retro encoder for retrieval-augmented pretraining, while disabling the Retro encoder for instruction tuning due to the lack of retrieved high-quality neighbors. To understand whether enabling the Retro encoder can further help the evaluation, we further conduct an ablation study and compare the zero-shot accuracy with or without the Retro encoder in Table 3 and 4. When enabling the Retro encoder, we put the top-2 neighbors in the encoder to align with the pretraining behavior.

From Table 3 and 4, the accuracy gap between the two variant is marginal. Disabling the Retro encoder yields very slightly better performance on average than when it is active. This suggests that although Retro is proficiently trained to infer both with and without the neighbors in the encoder, it is more optimal to align with the instruction tuning protocols and bypass the Retro encoder during evaluation. We think it is an important and promising future research direction to explore retrieval-augmented instruction tuning with the Retro encoder activated, especially when high-quality retrieval-augmented instruction data is available.

6 CONCLUSION

In this paper, we introduce InstructRetro 48B, the largest LLM with retrieval-augmented pretraining and instruction tuning. Specifically, we start from a pretrained GPT model, and continue pretrain the model with retrieval, which yields the retrieval-augmented foundation model Retro 48B. After applying instruction tuning to Retro, InstructRetro 48B unveils the potential of retrieval-augmented pretraining and demonstrates significant zero-shot accuracy improvement over its GPT counterpart through our extensive experiments on a wide range of open-ended QA tasks. Moreover, our novel findings show that only using the GPT decoder backbone of InstructRetro can achieve the very comparable accuracy, which sheds light on a promising direction to obtain a better GPT decoder for QA through retrieval-augmented pretraining before instruction tuning.

REFERENCES

- Yuntao Bai, Andy Jones, Kamal Ndousse, Amanda Askell, Anna Chen, Nova DasSarma, Dawn Drain, Stanislav Fort, Deep Ganguli, Tom Henighan, Nicholas Joseph, Saurav Kadavath, Jackson Kernion, Tom Conerly, Sheer El-Showk, Nelson Elhage, Zac Hatfield-Dodds, Danny Hernandez, Tristan Hume, Scott Johnston, Shauna Kravec, Liane Lovitt, Neel Nanda, Catherine Olsson, Dario Amodei, Tom Brown, Jack Clark, Sam McCandlish, Chris Olah, Ben Mann, and Jared Kaplan. Training a helpful and harmless assistant with reinforcement learning from human feedback. *arXiv preprint arXiv: 2204.05862*, 2022. URL <https://arxiv.org/abs/2204.05862v1>.
- Sebastian Borgeaud, Arthur Mensch, Jordan Hoffmann, Trevor Cai, Eliza Rutherford, Katie Millican, George Bm Van Den Driessche, Jean-Baptiste Lespiau, Bogdan Damoc, Aidan Clark, et al. Improving language models by retrieving from trillions of tokens. In *ICML*, 2022.
- Tom Brown, Benjamin Mann, Nick Ryder, Melanie Subbiah, Jared D Kaplan, Prafulla Dhariwal, Arvind Neelakantan, Pranav Shyam, Girish Sastry, Amanda Askell, et al. Language models are few-shot learners. *NeurIPS*, 2020a.
- Tom Brown, Benjamin Mann, Nick Ryder, Melanie Subbiah, Jared D Kaplan, Prafulla Dhariwal, Arvind Neelakantan, Pranav Shyam, Girish Sastry, Amanda Askell, et al. Language models are few-shot learners. *Advances in neural information processing systems*, 33:1877–1901, 2020b.
- Aakanksha Chowdhery, Sharan Narang, Jacob Devlin, Maarten Bosma, Gaurav Mishra, Adam Roberts, Paul Barham, Hyung Won Chung, Charles Sutton, Sebastian Gehrmann, et al. Palm: Scaling language modeling with pathways. *arXiv preprint arXiv:2204.02311*, 2022.
- Hyung Won Chung, Le Hou, Shayne Longpre, Barret Zoph, Yi Tay, William Fedus, Yunxuan Li, Xuezhi Wang, Mostafa Dehghani, Siddhartha Brahma, Albert Webson, Shixiang Shane Gu, Zhuyun Dai, Mirac Suzgun, Xinyun Chen, Aakanksha Chowdhery, Alex Castro-Ros, Marie Pellat, Kevin Robinson, Dasha Valter, Sharan Narang, Gaurav Mishra, Adams Yu, Vincent Zhao, Yanping Huang, Andrew Dai, Hongkun Yu, Slav Petrov, Ed H. Chi, Jeff Dean, Jacob Devlin, Adam Roberts, Denny Zhou, Quoc V. Le, and Jason Wei. Scaling instruction-finetuned language models. *arXiv preprint arXiv: 2210.11416*, 2022. URL <https://arxiv.org/abs/2210.11416v5>.
- Mike Conover, Matt Hayes, Ankit Mathur, Jianwei Xie, Jun Wan, Sam Shah, Ali Ghodsi, Patrick Wendell, Matei Zaharia, and Reynold Xin. Free dolly: Introducing the world’s first truly open instruction-tuned llm, 2023. URL <https://www.databricks.com/blog/2023/04/12/dolly-first-open-commercially-viable-instruction-tuned-llm>.
- Pradeep Dasigi, Nelson F. Liu, Ana Marasović, Noah A. Smith, and Matt Gardner. Quoref: A reading comprehension dataset with questions requiring coreferential reasoning. *Conference on Empirical Methods in Natural Language Processing*, 2019. doi: 10.18653/v1/D19-1606.
- Jacob Devlin, Ming-Wei Chang, Kenton Lee, and Kristina Toutanova. BERT: Pre-training of deep bidirectional transformers for language understanding. *arXiv preprint arXiv:1810.04805*, 2018.
- Nan Du, Yanping Huang, Andrew M. Dai, Simon Tong, Dmitry Lepikhin, Yuanzhong Xu, M. Krikun, Yanqi Zhou, A. Yu, Orhan Firat, Barret Zoph, L. Fedus, Maarten Bosma, Zongwei Zhou, Tao Wang, Yu Emma Wang, Kellie Webster, Marie Pellat, Kevin Robinson, K. Meier-Hellstern, Toju Duke, Lucas Dixon, Kun Zhang, Quoc V. Le, Yonghui Wu, Z. Chen, and Claire Cui. Glam: Efficient scaling of language models with mixture-of-experts. *International Conference on Machine Learning*, 2021. URL <https://arxiv.org/abs/2112.06905v2>.
- Dheeru Dua, Yizhong Wang, Pradeep Dasigi, Gabriel Stanovsky, Sameer Singh, and Matt Gardner. Drop: A reading comprehension benchmark requiring discrete reasoning over paragraphs. *North American Chapter of the Association for Computational Linguistics*, 2019. doi: 10.18653/v1/N19-1246.
- Angela Fan, Yacine Jernite, Ethan Perez, David Grangier, J. Weston, and Michael Auli. Eli5: Long form question answering. *Annual Meeting of the Association for Computational Linguistics*, 2019. doi: 10.18653/v1/P19-1346.

-
- Song Feng, H. Wan, R. Chulaka Gunasekara, S. Patel, Sachindra Joshi, and L. Lastras. doc2dial: A goal-oriented document-grounded dialogue dataset. *Conference on Empirical Methods in Natural Language Processing*, 2020. doi: 10.18653/v1/2020.emnlp-main.652.
- Leo Gao, Stella Biderman, Sid Black, Laurence Golding, Travis Hoppe, Charles Foster, Jason Phang, Horace He, Anish Thite, Noa Nabeshima, et al. The pile: An 800gb dataset of diverse text for language modeling. *arXiv preprint arXiv:2101.00027*, 2020.
- Tiezheng Ge, Kaiming He, Qifa Ke, and Jian Sun. Optimized product quantization. *IEEE Transactions on Pattern Analysis and Machine Intelligence*, 36(4):744–755, 2014. doi: 10.1109/TPAMI.2013.240.
- R.M. Gray and D.L. Neuhoff. Quantization. *IEEE Transactions on Information Theory*, 44(6): 2325–2383, 1998. doi: 10.1109/18.720541.
- Kelvin Guu, Kenton Lee, Zora Tung, Panupong Pasupat, and Mingwei Chang. REALM: Retrieval augmented language model pre-training. In *ICML*, 2020.
- Jordan Hoffmann, Sebastian Borgeaud, Arthur Mensch, Elena Buchatskaya, Trevor Cai, Eliza Rutherford, Diego de Las Casas, Lisa Anne Hendricks, Johannes Welbl, Aidan Clark, et al. Training compute-optimal large language models. *arXiv preprint arXiv:2203.15556*, 2022.
- Or Honovich, Thomas Scialom, Omer Levy, and Timo Schick. Unnatural instructions: Tuning language models with (almost) no human labor. *Annual Meeting of the Association for Computational Linguistics*, 2022. doi: 10.48550/arXiv.2212.09689.
- Jie Huang, Wei Ping, Peng Xu, Mohammad Shoeybi, Kevin Chen-Chuan Chang, and Bryan Catanzaro. Raven: In-context learning with retrieval augmented encoder-decoder language models. *arXiv preprint arXiv:2308.07922*, 2023.
- Gautier Izacard, Mathilde Caron, Lucas Hosseini, Sebastian Riedel, Piotr Bojanowski, Armand Joulin, and Edouard Grave. Unsupervised dense information retrieval with contrastive learning. *Transactions on Machine Learning Research*, 2022a.
- Gautier Izacard, Patrick Lewis, Maria Lomeli, Lucas Hosseini, Fabio Petroni, Timo Schick, Jane Dwivedi-Yu, Armand Joulin, Sebastian Riedel, and Edouard Grave. Atlas: Few-shot learning with retrieval augmented language models. *arXiv preprint arXiv: 2208.03299*, 2022b.
- Gautier Izacard, Patrick Lewis, Maria Lomeli, Lucas Hosseini, Fabio Petroni, Timo Schick, Jane Dwivedi-Yu, Armand Joulin, Sebastian Riedel, and Edouard Grave. Few-shot learning with retrieval augmented language models. *arXiv preprint arXiv:2208.03299*, 2022c.
- Jeff Johnson, Matthijs Douze, and Hervé Jégou. Billion-scale similarity search with GPUs. *IEEE Transactions on Big Data*, 7(3):535–547, 2019.
- Mandar Joshi, Eunsol Choi, Daniel S. Weld, and Luke Zettlemoyer. Triviaqa: A large scale distantly supervised challenge dataset for reading comprehension. *Annual Meeting of the Association for Computational Linguistics*, 2017. doi: 10.18653/v1/P17-1147.
- Vladimir Karpukhin, Barlas Oğuz, Sewon Min, Patrick Lewis, Ledell Wu, Sergey Edunov, Danqi Chen, and Wen-tau Yih. Dense passage retrieval for open-domain question answering. In *EMNLP*, 2020.
- Urvashi Khandelwal, Omer Levy, Dan Jurafsky, Luke Zettlemoyer, and Mike Lewis. Generalization through memorization: Nearest neighbor language models. 2020.
- Hyunwoo Kim, Jack Hessel, Liwei Jiang, Peter West, Ximing Lu, Youngjae Yu, Pei Zhou, Ronan Le Bras, Malihe Alikhani, Gunhee Kim, Maarten Sap, and Yejin Choi. Soda: Million-scale dialogue distillation with social commonsense contextualization. *arXiv preprint arXiv: 2212.10465*, 2022. URL <https://arxiv.org/abs/2212.10465v2>.
- Diederik P. Kingma and Jimmy Ba. Adam: A method for stochastic optimization, 2014.

-
- Tomáš Kočiský, Jonathan Schwarz, Phil Blunsom, Chris Dyer, Karl Moritz Hermann, Gábor Melis, and Edward Grefenstette. The narrativeqa reading comprehension challenge. *Transactions of the Association for Computational Linguistics*, 6:317–328, 2018.
- Taku Kudo and John Richardson. Sentencepiece: A simple and language independent subword tokenizer and detokenizer for neural text processing. *Conference on Empirical Methods in Natural Language Processing*, 2018. doi: 10.18653/v1/D18-2012.
- Tom Kwiatkowski, Jennimaria Palomaki, Olivia Redfield, Michael Collins, Ankur Parikh, Chris Alberti, Danielle Epstein, Illia Polosukhin, Jacob Devlin, Kenton Lee, Kristina Toutanova, Llion Jones, Matthew Kelcey, Ming-Wei Chang, Andrew M. Dai, Jakob Uszkoreit, Quoc Le, and Slav Petrov. Natural questions: A benchmark for question answering research. *Transactions of the Association for Computational Linguistics*, 7:452–466, 2019. doi: 10.1162/tacl_a_00276. URL <https://aclanthology.org/Q19-1026>.
- Andreas Köpf, Yannic Kilcher, Dimitri von Rütte, Sotiris Anagnostidis, Zhi-Rui Tam, Keith Stevens, Abdullah Barhoum, Nguyen Minh Duc, Oliver Stanley, Richárd Nagyfi, Shahul ES, Sameer Suri, David Glushkov, Arnav Dantuluri, Andrew Maguire, Christoph Schuhmann, Huu Nguyen, and Alexander Mattick. Openassistant conversations - democratizing large language model alignment. *arXiv preprint arXiv: 2304.07327*, 2023.
- Hugo Laurençon, Lucile Saulnier, Thomas Wang, Christopher Akiki, Albert Villanova del Moral, Teven Le Scao, Leandro Von Werra, Chenghao Mou, Eduardo González Ponferrada, Huu Nguyen, et al. The bigscience roots corpus: A 1.6 tb composite multilingual dataset. *Advances in Neural Information Processing Systems*, 35:31809–31826, 2022.
- Patrick Lewis, Ethan Perez, Aleksandra Piktus, Fabio Petroni, Vladimir Karpukhin, Naman Goyal, Heinrich Küttler, Mike Lewis, Wen-tau Yih, Tim Rocktäschel, et al. Retrieval-augmented generation for knowledge-intensive NLP tasks. In *NeurIPS*, 2020.
- S. Longpre, Le Hou, Tu Vu, Albert Webson, Hyung Won Chung, Yi Tay, Denny Zhou, Quoc V. Le, Barret Zoph, Jason Wei, and Adam Roberts. The flan collection: Designing data and methods for effective instruction tuning. *International Conference on Machine Learning*, 2023. doi: 10.48550/arXiv.2301.13688.
- Yu A Malkov and Dmitry A Yashunin. Efficient and robust approximate nearest neighbor search using hierarchical navigable small world graphs. *IEEE transactions on pattern analysis and machine intelligence*, 42(4):824–836, 2018.
- Swaroop Mishra, Daniel Khashabi, Chitta Baral, and Hannaneh Hajishirzi. Cross-task generalization via natural language crowdsourcing instructions. In *ACL*, 2022.
- Reiichiro Nakano, Jacob Hilton, Suchir Balaji, Jeff Wu, Long Ouyang, Christina Kim, Christopher Hesse, Shantanu Jain, Vineet Kosaraju, William Saunders, et al. WebGPT: Browser-assisted question-answering with human feedback. *arXiv preprint arXiv:2112.09332*, 2021.
- OpenAI. ChatGPT. <https://chat.openai.com>, 2022.
- OpenAI. GPT-4 technical report. *arXiv*, 2023.
- Long Ouyang, Jeffrey Wu, Xu Jiang, Diogo Almeida, Carroll Wainwright, Pamela Mishkin, Chong Zhang, Sandhini Agarwal, Katarina Slama, Alex Ray, et al. Training language models to follow instructions with human feedback. *NeurIPS*, 2022.
- Jack W Rae, Sebastian Borgeaud, Trevor Cai, Katie Millican, Jordan Hoffmann, Francis Song, John Aslanides, Sarah Henderson, Roman Ring, Susannah Young, et al. Scaling language models: Methods, analysis & insights from training gopher. *arXiv preprint arXiv:2112.11446*, 2021.
- Colin Raffel, Noam Shazeer, Adam Roberts, Katherine Lee, Sharan Narang, Michael Matena, Yanqi Zhou, Wei Li, Peter J Liu, et al. Exploring the limits of transfer learning with a unified text-to-text transformer. *Journal of Machine Learning Research*, 2020.

-
- Pranav Rajpurkar, Jian Zhang, Konstantin Lopyrev, and Percy Liang. Squad: 100,000+ questions for machine comprehension of text. *Conference on Empirical Methods in Natural Language Processing*, 2016. doi: 10.18653/v1/D16-1264.
- Pranav Rajpurkar, Robin Jia, and Percy Liang. Know what you don’t know: Unanswerable questions for squad. *Annual Meeting of the Association for Computational Linguistics*, 2018. doi: 10.18653/v1/P18-2124.
- Victor Sanh, Albert Webson, Colin Raffel, Stephen Bach, Lintang Sutawika, Zaid Alyafeai, Antoine Chaffin, Arnaud Stiegler, Arun Raja, Manan Dey, M Saiful Bari, Canwen Xu, Urmish Thakker, Shanya Sharma Sharma, Eliza Szczechla, Taewoon Kim, Gunjan Chhablani, Nihal Nayak, Debajyoti Datta, Jonathan Chang, Mike Tian-Jian Jiang, Han Wang, Matteo Manica, Sheng Shen, Zheng Xin Yong, Harshit Pandey, Rachel Bawden, Thomas Wang, Trishala Neeraj, Jos Rozen, Abheesht Sharma, Andrea Santilli, Thibault Fevry, Jason Alan Fries, Ryan Teehan, Teven Le Scao, Stella Biderman, Leo Gao, Thomas Wolf, and Alexander M Rush. Multitask prompted training enables zero-shot task generalization. In *International Conference on Learning Representations*, 2022a. URL <https://openreview.net/forum?id=9Vrb9D0WI4>.
- Victor Sanh, Albert Webson, Colin Raffel, Stephen H Bach, Lintang Sutawika, Zaid Alyafeai, Antoine Chaffin, Arnaud Stiegler, Teven Le Scao, Arun Raja, et al. Multitask prompted training enables zero-shot task generalization. In *ICLR*, 2022b.
- Shaden Smith, Mostofa Patwary, Brandon Norick, Patrick LeGresley, Samyam Rajbhandari, Jared Casper, Zhun Liu, Shrimai Prabhunoye, George Zerveas, Vijay Korthikanti, Elton Zhang, Rewon Child, Reza Yazdani Aminabadi, Julie Bernauer, Xia Song, Mohammad Shoeybi, Yuxiong He, Michael Houston, Saurabh Tiwary, and Bryan Catanzaro. Using deepspeed and megatron to train megatron-turing nlg 530b, a large-scale generative language model. *arXiv*, 2022.
- Romal Thoppilan, Daniel De Freitas, Jamie Hall, Noam Shazeer, Apoorv Kulshreshtha, Heng-Tze Cheng, Alicia Jin, Taylor Bos, Leslie Baker, Yu Du, et al. Lamda: Language models for dialog applications. *arXiv preprint arXiv:2201.08239*, 2022.
- Hugo Touvron, Thibaut Lavril, Gautier Izacard, Xavier Martinet, Marie-Anne Lachaux, Timothée Lacroix, Baptiste Rozière, Naman Goyal, Eric Hambro, Faisal Azhar, Aurelien Rodriguez, Armand Joulin, Edouard Grave, and Guillaume Lample. Llama: Open and efficient foundation language models. *ARXIV*, 2023a. URL <https://arxiv.org/abs/2302.13971v1>.
- Hugo Touvron, Louis Martin, Kevin Stone, Peter Albert, Amjad Almahairi, Yasmine Babaei, Nikolay Bashlykov, Soumya Batra, Prajjwal Bhargava, Shrutu Bhosale, Dan Bikel, Lukas Blecher, Cristian Canton Ferrer, Moya Chen, Guillem Cucurull, David Esiobu, Jude Fernandes, Jeremy Fu, Wenyin Fu, Brian Fuller, Cynthia Gao, Vedanuj Goswami, Naman Goyal, Anthony Hartshorn, Saghar Hosseini, Rui Hou, Hakan Inan, Marcin Kardas, Viktor Kerkez, Madian Khabsa, Isabel Kloumann, Artem Korenev, Punit Singh Koura, Marie-Anne Lachaux, Thibaut Lavril, Jenya Lee, Diana Liskovich, Yinghai Lu, Yuning Mao, Xavier Martinet, Todor Mihaylov, Pushkar Mishra, Igor Molybog, Yixin Nie, Andrew Poulton, Jeremy Reizenstein, Rashi Rungta, Kalyan Saladi, Alan Schelten, Ruan Silva, Eric Michael Smith, Ranjan Subramanian, Xiaoqing Ellen Tan, Binh Tang, Ross Taylor, Adina Williams, Jian Xiang Kuan, Puxin Xu, Zheng Yan, Iliyan Zarov, Yuchen Zhang, Angela Fan, Melanie Kambadur, Sharan Narang, Aurelien Rodriguez, Robert Stojnic, Sergey Edunov, and Thomas Scialom. Llama 2: Open foundation and fine-tuned chat models. *arXiv preprint arXiv: 2307.09288*, 2023b. URL <https://arxiv.org/abs/2307.09288v2>.
- A. Trischler, Tong Wang, Xingdi Yuan, Justin Harris, Alessandro Sordani, Philip Bachman, and Kaheer Suleman. Newsqa: A machine comprehension dataset. *REP4NLP@ACL*, 2016. doi: 10.18653/v1/W17-2623.
- Ashish Vaswani, Noam Shazeer, Niki Parmar, Jakob Uszkoreit, Llion Jones, Aidan N Gomez, Łukasz Kaiser, and Illia Polosukhin. Attention is all you need. In *NIPS*, 2017.
- Boxin Wang, Wei Ping, Peng Xu, Lawrence McAfee, Zihan Liu, Mohammad Shoeybi, Yi Dong, Oleksii Kuchaiev, Bo Li, Chaowei Xiao, et al. Shall we pretrain autoregressive language models with retrieval? a comprehensive study. *arXiv preprint arXiv:2304.06762*, 2023a.

-
- Yizhong Wang, Yeganeh Kordi, Swaroop Mishra, Alisa Liu, Noah A. Smith, Daniel Khashabi, and Hannaneh Hajishirzi. Self-instruct: Aligning language models with self-generated instructions. *Annual Meeting of the Association for Computational Linguistics*, 2022. doi: 10.48550/arXiv.2212.10560.
- Yizhong Wang, Hamish Ivison, Pradeep Dasigi, Jack Hessel, Tushar Khot, Khyathi Raghavi Chandu, David Wadden, Kelsey MacMillan, Noah A. Smith, Iz Beltagy, and Hannaneh Hajishirzi. How far can camels go? exploring the state of instruction tuning on open resources. *arXiv preprint arXiv:2306.04751*, 2023b. URL <https://arxiv.org/abs/2306.04751v1>.
- Jason Wei, Maarten Bosma, Vincent Y Zhao, Kelvin Guu, Adams Wei Yu, Brian Lester, Nan Du, Andrew M Dai, and Quoc V Le. Finetuned language models are zero-shot learners. In *ICLR*, 2022a.
- Jason Wei, Yi Tay, Rishi Bommasani, Colin Raffel, Barret Zoph, Sebastian Borgeaud, Dani Yogatama, Maarten Bosma, Denny Zhou, Donald Metzler, et al. Emergent abilities of large language models. *arXiv preprint arXiv:2206.07682*, 2022b.
- Jason Wei, Xuezhi Wang, Dale Schuurmans, Maarten Bosma, Fei Xia, Ed Chi, Quoc V Le, Denny Zhou, et al. Chain-of-thought prompting elicits reasoning in large language models. *Advances in Neural Information Processing Systems*, 35:24824–24837, 2022c.
- Dani Yogatama, Cyprien de Masson d’Autume, and Lingpeng Kong. Adaptive semiparametric language models. *Transactions of the Association for Computational Linguistics*, 2021.

A PRETRAINING DETAILS

A.1 PRETRAINING CORPUS

We prepared a pretraining dataset consisting of around 1.2 trillion tokens from English natural language data. Specifically, it consists of web-crawl data from Common Crawl, news data, conversational data, book data (e.g., Book3 and Book-Corpus2 from the Pile dataset (Gao et al., 2020)), scientific and multi-domain data (e.g., Wikipedia and the BigScience ROOTS corpus (Laurençon et al., 2022)).

A.2 CONTINUED PRETRAINING SCHEDULES

Based on pretrained GPT models, we further pretrain Retro with retrieval augmentation on additional 100 billion tokens, which is around 25M samples with sequence length set to 4096. We list the pretraining hyper-parameter details of Retro-fitting in Table 5. GPT-fitting uses the same training schedules as Retro-fitting.

All models use Adam optimizer (Kingma & Ba, 2014) with $\beta_1 = 0.9$ and $\beta_2 = 0.95$. We employ the learning rate (LR) decay schedules with LR warmup samples of 16667 and LR decay samples of 23750000.

Table 5: Detailed pretraining setup for standard pre-trained LMs and InstructRetro.

Models Size	LR	min LR	LR Decay Styles	Batch Size	Pretraining Steps
823M	2e-5	2e-6	cosine	128	195.2k
2.25B	2e-5	2e-6	cosine	256	97.6k
8.5B	1e-5	1e-6	cosine	512	48.8K
22B	1e-5	1e-6	cosine	512	48.8K
43B	9e-6	9e-7	cosine	768	32.5k

B DETAILS OF RETRIEVAL DATABASE

Retrieval Database. We use the whole pertaining corpus as our retrieval database, consisting of 1.2 trillion tokens as mentioned in Appendix §A.1. Our pertaining dataset with 1.2 trillion tokens yields a retrieval database consisting of 19B chunks in total with chunk size $m = 64$. To support fast similarity searches with billions of chunks, we implement the database index with Faiss index (Johnson et al., 2019). Given the BERT embeddings of an input chunk C_i , Faiss can return the approximate k nearest neighbor of C_i within a few milliseconds.

Faiss Index configuration We use the Faiss index (Johnson et al., 2019) as the implementation for the dense retriever to search for approximate nearest neighbors in the BERT embedding space. We configure the Faiss index as follows:

- **Preprocessing:** We use Optimized Product Quantization (Ge et al., 2014) to apply a rotation to the input vectors to make them more amenable to PQ coding (Gray & Neuhoff, 1998).
- **Indexer:** We use Inverted File Index (IVF) with 2^{22} centroids and accelerate it with Hierarchical Navigable Small World (HNSW) graphs (Malkov & Yashunin, 2018).
- **Encoding:** We adopt PQ encoding that compresses the dense embedding vector into 64 bits.

As a result, we can achieve $4ms$ per query over the whole pretraining corpus via batch queries averaged for each chunk with less than 1TB memory usage as our max throughput. Given a single query, the latency of the response is around $0.1s$ per query. We also note that increasing the number of K in the query does not yield slower query speed. During pertaining, we follow Borgeaud et al. (2022) to pre-compute the nearest neighbors and save the data for pretraining.

C QUALITATIVE EXAMPLES

C.1 AN EXAMPLE FROM THE INSTRUCTION TUNING DATA

Table 6 below is a data example from the instruction tuning data.

Table 6: A sample conversation from our instruction tuning dataset. The black part serves as the context, while the blue part is masked as the answer mask, on which the LM loss is computed.

Speaker	Conversation
System	This is a chat between a user and an artificial intelligence assistant. The assistant gives helpful, detailed, and polite answers to the user’s questions based on the context. The assistant should also indicate when the answer cannot be found in the context.
User	My bicycle tire has a puncture and while I have a pump with me, I don’t have a patch repair kit. Is there a way to keep the tire from running out of air until I can get to a bicycle shop?
Assistant	Yes, you could use duct tape to seal the puncture.
User	Can you give me a tutorial on how to use the duct tape to seal the puncture?
Assistant	Sure, here’s a tutorial on how to use duct tape to seal a puncture in a tire: 1. Start by cleaning the area around the puncture with a damp cloth. 2. Cut a piece of duct tape large enough to cover the puncture, plus a few millimeters of extra. 3. Remove the backing from the duct tape, and press it firmly over the puncture. 4. Rub the tape firmly with your fingers to ensure a good seal. 5. You can also use a roller or a flat item like a ruler to make sure that the tape is pressed firmly against the puncture. 6. Trim away any excess tape, and your puncture should now be sealed.

C.2 AN EXAMPLE FROM THE DOWNSTREAM QA DATASET: SQUAD 1.1

We re-format all of the QA tasks in the conversational format. An example from the SQuAD 1.1 dataset with the conversational format is shown in the Table 7 below.

Table 7: A sample conversation prompt template from the SQuAD 1.1 dataset.

Speaker	Conversation
System	System: This is a chat between a user and an artificial intelligence assistant. The assistant gives helpful, detailed, and polite answers to the user’s questions based on the context. The assistant should also indicate when the answer cannot be found in the context.
User	title: , source: The pound-force has a metric counterpart, less commonly used than the newton: the kilogram-force (kgf) (sometimes kilopond), is the force exerted by standard gravity on one kilogram of mass. The kilogram-force leads to an alternate, but rarely used unit of mass: the metric slug (sometimes mug or hyl) is that mass that accelerates at 1 ms ⁻² when subjected to a force of 1 kgf. The kilogram-force is not a part of the modern SI system, and is generally deprecated; however it still sees use for some purposes as expressing aircraft weight, jet thrust, bicycle spoke tension, torque wrench settings and engine output torque. Other arcane units of force include the sthène, which is equivalent to 1000 N, and the kip, which is equivalent to 1000 lbf. Based on the above article, answer a question. What is the seldom used force unit equal to one thousand newtons?
Assistant	The answer is

D ADDITIONAL EXPERIMENTAL RESULTS

D.1 DOWNSTREAM TASK ACCURACY OF PRETRAINED MODELS BEFORE INSTRUCTION TUNING

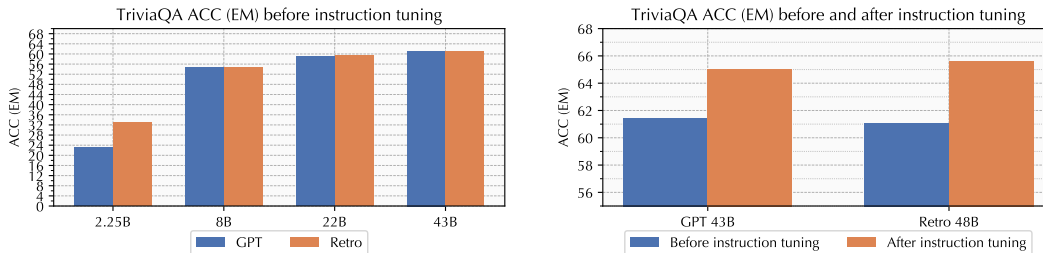

(a) Before instruction tuning, the improvement of retrieval augmentation saturates when the size scales up.

(b) Instruction tuning further unveils the potential of retrieval augmentation even when the size scales up.

Figure 6: Zero-shot accuracy (EM) of GPT and Retro before and after instruction tuning evaluated on the TriviaQA dataset.